

Air Operated Double Diaphragm Pump

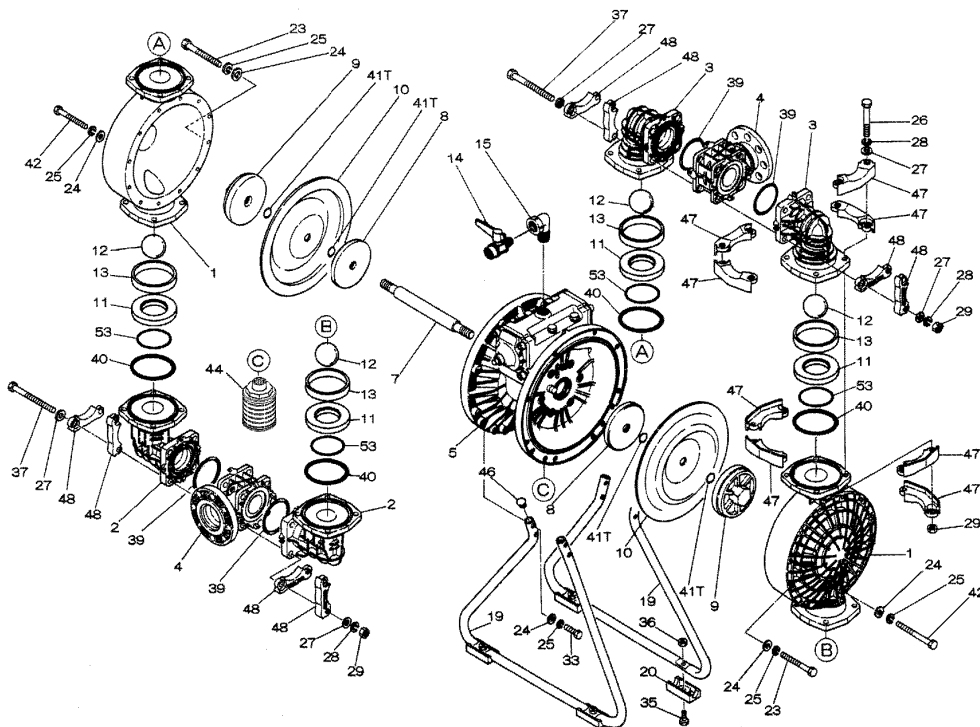

Parts List

Ref. No.	Description	Qty	Part No.
1	Out Chamber	2	780149
2	In Manifold	2	780246
3	Out Manifold	2	780152
4	Center Manifold	2	780250
5	Body Assembly	1	803113
7	Center Rod	1	711940
8	Center Disk	2	711041
9	Center Disk	2	771730
10	Diaphragm	2	770934
11	Valve Seat	4	772098
12	Ball	4	770694
13	Valve Guide	4	772099
14	Ball Valve	1	684322
15	Elbow	1	682523
19	Stand Body	2	711927
20	Cushion	4	771865
23	Bolt	20	683543
24	Plain Washer	32	631330
25	Spring Lock Washer	32	680257
26	Bolt	16	621213
27	Plain Washer	32	631331
28	Spring Lock Washer	24	680607
29	Nut	24	628014
33	Bolt	8	621179
35	Bolt	4	621149
36	Nut with Flange	4	683837
37	Bolt	8	683544
39	O-ring	4	643070
40	O-ring	4	643080
41T	O-Ring	4	643015
42	Bolt	4	683552
44	Muffler	1	804764
46	Cap	4	683641
47	Protector A	32	771789
48	Protector B	24	771790
53	O-ring	4	643143

Repair Kits

K80-PT Liquid Side Kit includes the following:

Ref. No.	Description	Qty	Part No.
10	Diaphragm	2	770934
12	Ball	4	770694
40	O-ring	4	643080
53	O-ring	4	643143
41T	O-Ring	4	643015

K80-AM Air Side Kit includes the following:

Ref. No.	Description	Qty	Part No.
5-3	Throat Bearing	2	772689
5-4	Spring	2	711937
5-5	Valve Seat	2	771740
5-6	Pilot Valve Assembly	2	832163
5-8	O-ring	2	640020
5-9	Packing	2	685444
5-10	O-ring	2	640029
5-11	Gasket	2	771742
5-14	Gasket	1	771712
5-13-8	Gasket	2	771738
5-13-12	C-Spool Assy (CF)	1	805084

Air Operated Double Diaphragm Pump

803113 Body Assembly

Ref. No.	Description	Qty	Part No.
5-1	Air Chamber	2	711935
5-2	Body	1	711936
5-3	Throat Bearing	2	772689
5-4	Spring	2	711937
5-5	Valve Seat	2	771740
5-6	Pilot Valve Assembly	2	832163
5-8	O-ring	2	640020
5-9	Packing	2	685444
5-10	O-ring	2	640029
5-11	Gasket	2	771742
5-12	Flat Head Bolt	12	683812
5-13	Valve Body Assembly	1	802971
5-14	Gasket	1	771712
5-15	Bolt	6	684240
5-18	Plain Washer	12	684987

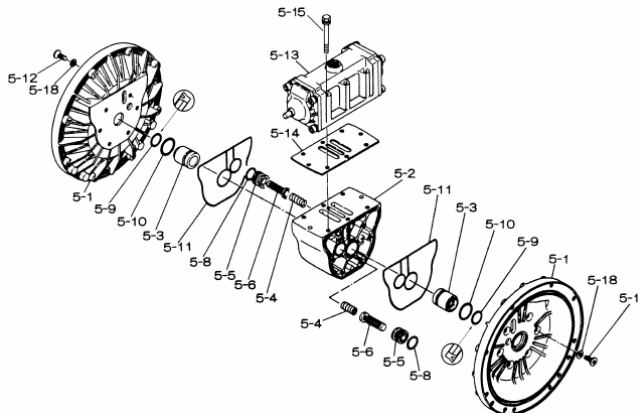

802971 Air Valve Body Assembly

Ref. No.	Description	Qty	Part No.
5-13-1	Valve Body	1	711931
5-13-2	Cap A	1	580999
5-13-3	Cap B	1	581000
5-13-5	Spring Stopper	1	771735
5-13-6	Reset Button	1	712976
5-13-8	Gasket	2	771738
5-13-9	Bolt	8	685036
5-13-12	C-Spool Assy (CF)	1	805084
5-13-12*1 Sleeve	Sleeve Assembly	1	803675
5-13-13	O-ring	1	640005
5-13-14	Cushion	4	684128

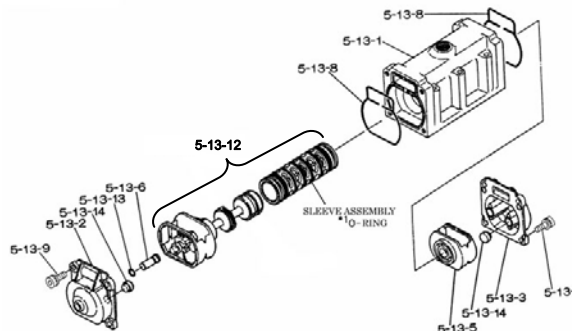

805084 C-Spool Assembly (CF)

Ref. No.	Description	Qty	Part No.
A	Sleeve Assy.	1	803675
B	O-ring (sleeve)	6	640036
C	Spool Assy (CF)	1	805085
D	Spring Retainer	1	771735
E	C-Spring	2	711932
F	Block	1	771734

