

# EXPLODED VIEW & PARTS LISTING

## Air Operated Double Diaphragm Pump

Model: NDP-50BV  
Kynar Series  
(w/metal center body)

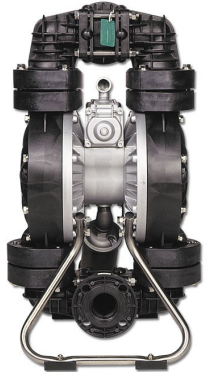

### To Purchase:

- 800-990-7867
- sales@yamadapump.com
- Find My Rep

### More Information:

- YouTube: @yamadapump
- yamadapump.com
- Data Sheets | CAD Drawings | Manuals Literature | BOM | Performance Curves

### Trial Program

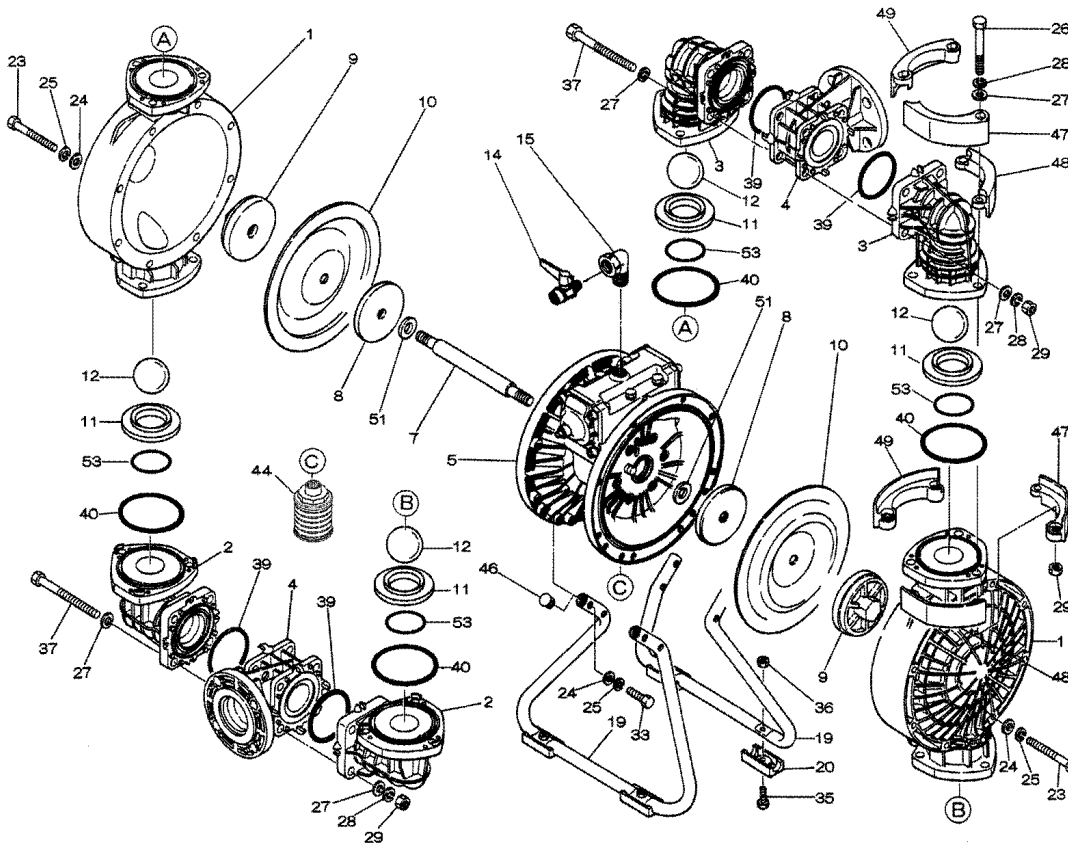

■Body Assembly



■Valve Body Assembly

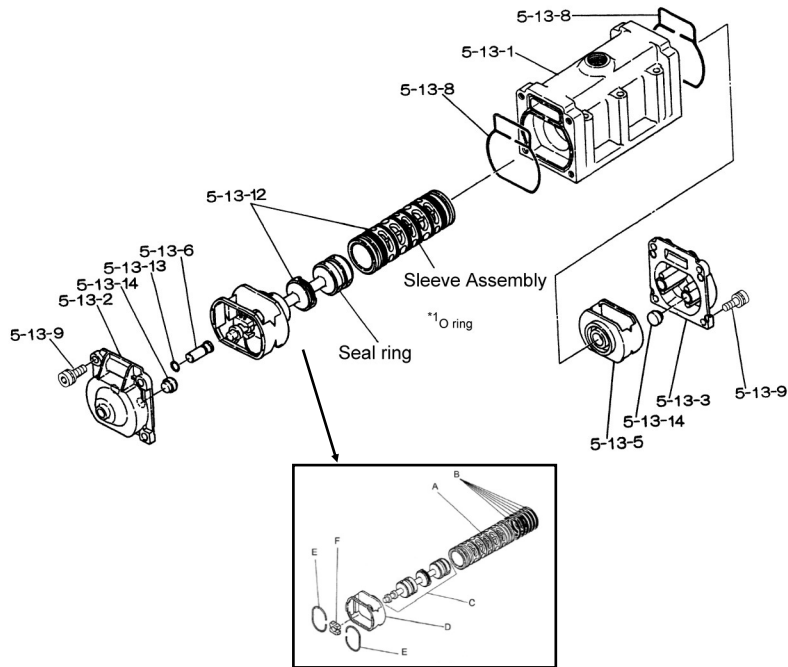

	NDP-50BVE	NDP-50BVH	NDP-50BVS	NDP-50BVV			
	852813	852489	852775	852812			
REF.NO.	PARTS#	PARTS#	PARTS#	PARTS#	DESCRIPTION	QTY	REORDER
1	780153	780153	780153	780153	OUT CHAMBER 50PVDF-2	2	
2	780252	780252	780252	780252	IN MANIFOLD 50PVDF	2	
3	780154	780154	780154	780154	OUT MANIFOLD 50PVDF-2	2	
4	780115	780115	780115	780115	CENTER MANIFOLD 50PVDF	2	
<b>5</b>	<b>803112</b>	<b>803112</b>	<b>803112</b>	<b>803112</b>	<b>CENTER BODY ASSY 50</b>	<b>1</b>	
5- 1	711934	711934	711934	711934	AIR CHAMBER 50	2	
5- 2	711936	711936	711936	711936	BODY	1	
5- 3	772689	772689	772689	772689	THROAT BEARING	2	
5- 4	711937	711937	711937	711937	PILOT VALVE SPRING	2	
5- 5	771740	771740	771740	771740	PILOT VALVE SEAT	2	
5- 6	832162	832162	832162	832162	PILOT VALVE ASSY	2	
5- 8	640020	640020	640020	640020	O-RING	2	
5- 9	685444	685444	685444	685444	V-PACKING 40/50/80	2	
5-10	640029	640029	640029	640029	O-RING	2	
5-11	771742	771742	771742	771742	GASKET 40/50/80	2	
5-12	683812	683812	683812	683812	M8X1.25X20 FLAT SOCKET	12	
<b>5-13</b>	<b>802971</b>	<b>802971</b>	<b>802971</b>	<b>802971</b>	<b>VALVE BODY ASSY.</b>	<b>1</b>	
5-13- 1	711931	711931	711931	711931	VALVE BODY 40/50/80	1	
5-13- 2	580999	580999	580999	580999	CAP A 40/50/80	1	
5-13- 3	581000	581000	581000	581000	CAP B 40/50/80	1	
5-13- 5	771735	771735	771735	771735	SPRING RETAINER	1	
5-13- 6	712976	712976	712976	712976	RESET BUTTON 40/50/80	1	
5-13- 8	771738	771738	771738	771738	GASKET	2	
5-13- 9	685036	685036	685036	685036	SOCKET BOLT M8X20 W/ W	8	
<b>5-13-12</b>	<b>805084</b>	<b>805084</b>	<b>805084</b>	<b>805084</b>	<b>C SPOOL ASSY.</b>	<b>1</b>	
A	803675	803675	803675	803675	SLEEVE ASSY.	1	
B	640036	640036	640036	640036	O-RING	6	
C	805085	805085	805085	805085	SPOOL ASSY.	1	
D	771735	771735	771735	771735	SPRING RETAINER	1	
E	711932	711932	711932	711932	C-SPRING	2	
F	771734	771734	771734	771734	BLOCK	1	
5-13-13	640005	640005	640005	640005	O-RING	1	
5-13-14	684128	684128	684128	684128	CUSHION 40/50/80 CAP	4	
5-14	771712	771712	771712	771712	GASKET FOR VALVE BODY	1	
5-15	684240	684240	684240	684240	BOLT W/ WASHERS M8X85	6	
5-18	684987	684987	684987	684987	WASHER	12	
7	711900	711900	711900	711900	CENTER ROD 40/50	1	
8	711904	711904	711904	711904	CENTER DISK 50-R	2	
9	771901	771901	771901	771901	CENTER DISK 50PVDF-R	2	
10	771856	771703	771976	771800	DIAPHRAGM 50	2	
11	772100	772100	772100	772100	VALVE SEAT 50	4	
12	770633	773143	773173	770636	BALL 50	4	
14	686974	686974	686974	686974	BALL VALVE 50/80 3/4"	1	
15	682523	682523	682523	682523	ELBOW STRT 3/4" 90D	1	
19	711926	711926	711926	711926	STAND 50PP	2	
20	771865	771865	771865	771865	FOOT RUBBER	4	
23	686156	686156	686156	686156	BOLT	16	

	NDP-50BVE	NDP-50BVH	NDP-50BVS	NDP-50BVV			
	852813	852489	852775	852812			
REF.NO.	PARTS#	PARTS#	PARTS#	PARTS#	DESCRIPTION	QTY	REORDER
24	631330	631330	631330	631330	FLAT WASHER	24	
25	680257	680257	680257	680257	SPRING WASHER	24	
26	621213	621213	621213	621213	BOLT	12	
27	631331	631331	631331	631331	FLAT WASHER	32	
28	680607	680607	680607	680607	SPRING WASHER	20	
29	628014	628014	628014	628014	NUT	20	
33	621179	621179	621179	621179	BOLT	8	
35	621149	621149	621149	621149	BOLT	4	
36	683837	683837	683837	683837	NUT W/FLANGE	4	
37	684592	684592	684592	684592	BOLT	8	
39	684121	771899	771899	642064	O-RING	4	
40	684122	772063	772063	642069	O-RING	4	
44	804764	804764	804764	804764	SILENCER ASSY	1	
46	683641	683641	683641	683641	CAP 40/50/80PP STAND	4	
47	771786	771786	771786	771786	PROTECTOR A 50PP&PVDF	8	
48	771787	771787	771787	771787	PROTECTOR B 50PP&PVDF	8	
49	771788	771788	771788	771788	PROTECTOR C 50PP&PVDF	8	
51	770582	770582	770582	770582	CUSHION 40/50/80	2	
53	685448	643139	643139	642139	O-RING	4	
KIT	K50-VE	K50-VH	K50-VS	K50-VV	LIQUID END KIT		
KIT	K45-AM				AIR MOTOR KIT		

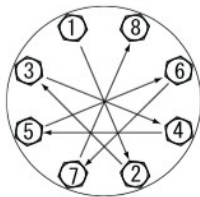

**Tightening torque for center rod and out chambers.**

Center Rod                      36 ft-lbf {50 N-m}  
Out Chambers                    26 ft-lbf {35 N-m}

**Tightening torque for manifold retainer bolts.**  
BVE/H/S/V                      15 ft-lbf {20 N-m}

**General Tools:**

- Socket wrenches - 13mm, 17mm, 19mm
- Hexagonal box wrench - 5mm, 6mm
- Small crowbars - 2 (C/N/E/V)
- Plastic hammer

**Special Tools (sold separately):**

- Sleeve remover (713180).
- PP wrench to remove the center disk (771868)

**Miscellaneous:**

- Assembly Oil - turbine oil none additional class 1 (equivalent to ISO VG32 grade)
- Nuts - M16 x 1.5
- Thread locker
- Urea grease grade (NLGI) No. 2

<b>Customer Notes</b>	
Model #:	_____
Description:	_____
Serial #:	_____
Date Installed:	_____
Department Location:	_____
Tag/Project:	_____