

Air Operated Double Diaphragm Pump

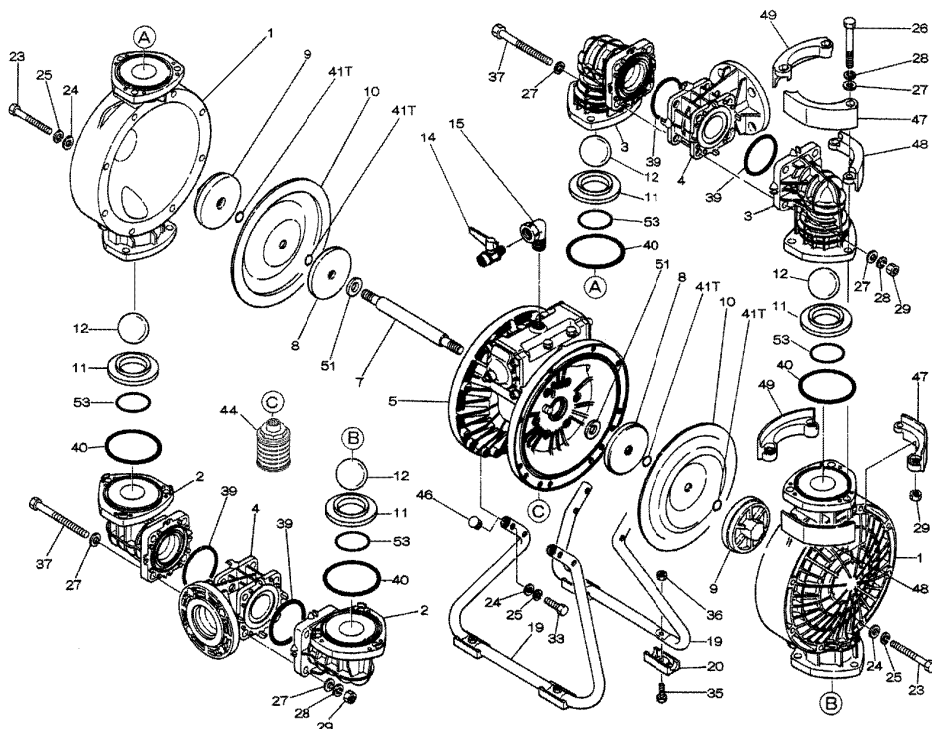

Parts List

Ref. No.	Description	Qty	Part No.
1	Out Chamber	2	780153
2	In Manifold	2	780252
3	Out Manifold	2	780154
4	Center Manifold	2	780155
5	Body Assembly	1	803112
7	Center Rod	1	711939
8	Center Disk	2	707822
9	Center Disk	2	780116
10	Diaphragm	2	770815
11	Valve Seat	4	772100
12	Ball	4	770693
14	Ball Valve	1	684322
15	Elbow	1	682523
19	Stand Body	2	711926
20	Cushion	4	771865
23	Bolt	16	686156
24	Plain Washer	24	631330
25	Spring Lock Washer	24	680257
26	Bolt	12	621213
27	Plain Washer	28	631331
28	Spring Lock Washer	20	680607
29	Nut	20	628014
33	Bolt	8	621179
35	Bolt	4	621149
36	Nut with Flange	4	683837
37	Bolt	8	684592
39	O-ring	4	771899
40	O-ring	4	772063
41T	O-ring	4	643015
44	Muffler	1	804764
46	Cap	4	683641
47	Protector A	8	771786
48	Protector B	8	771787
49	Protector C	8	771788
53	O-ring	4	643139

Repair Kits

K50-VT Liquid Side Kit includes the following:

Ref. No.	Description	Qty	Part No.
10	Diaphragm	2	770815
12	Ball	4	770693
40	O-ring	4	772063
41T	O-ring	4	643015
53	O-ring	4	643139

K45-AM Air Side Kit includes the following:

Ref. No.	Description	Qty	Part No.
5-3	Throat Bearing	2	772689
5-4	Spring	2	711937
5-5	Valve Seat	2	771740
5-6	Pilot Valve Assembly	2	832162
5-8	O-ring	2	640020
5-9	Packing	2	685444
5-10	O-ring	2	640029
5-11	Gasket	2	771742
5-14	Gasket	1	771712
5-13-8	Gasket	2	771738
5-13-12	C-Spool Assy (CF)	1	805084

Air Operated Double Diaphragm Pump

803112 Body Assembly

Ref. No.	Description	Qty	Part No.
5-1	Air Chamber	2	711934
5-2	Body	1	711936
5-3	Throat Bearing	2	772689
5-4	Spring	2	711937
5-5	Valve Seat	2	771740
5-6	Pilot Valve Assembly	2	832162
5-8	O-ring	2	640020
5-9	Packing	2	685444
5-10	O-ring	2	640029
5-11	Gasket	2	771742
5-12	Flat Head Bolt	12	683812
5-13	Valve Body Assembly	1	802971
5-14	Gasket	1	771712
5-15	Bolt	6	684240
5-18	Plain Washer	12	684987



802971 Air Valve Body Assembly

Ref. No.	Description	Qty	Part No.
5-13-1	Valve Body	1	711931
5-13-2	Cap A	1	580999
5-13-3	Cap B	1	581000
5-13-5	Spring Stopper	1	771735
5-13-6	Reset Button	1	712976
5-13-8	Gasket	2	771738
5-13-9	Bolt	8	685036
5-13-12	C-Spool Assy (CF)	1	805084
5-13-12 *1 Sleeve	Sleeve Assembly	1	803675
5-13-13	O-ring	1	640005
5-13-14	Cushion	4	684128



805084 C-Spool Assembly (CF)

Ref. No.	Description	Qty	Part No.
A	Sleeve Assy.	1	803675
B	O-ring (sleeve)	6	640036
C	Spool Assy (CF)	1	805085
D	Spring Retainer	1	771735
E	C-Spring	2	711932
F	Block	1	771734

