

EXPLODED VIEW & PARTS LISTING

Air Operated Double Diaphragm Pump

Model: NDP-50BV-PP
Kynar Series



To Purchase:

- ☎ 800-990-7867
- ✉ sales@yamadapump.com
- 📍 Find My Rep

More Information:

- ▶ YouTube: @yamadapump
- 🌐 yamadapump.com
- Data Sheets | CAD Drawings | Manuals Literature | BOM | Performance Curves*

Trial Program

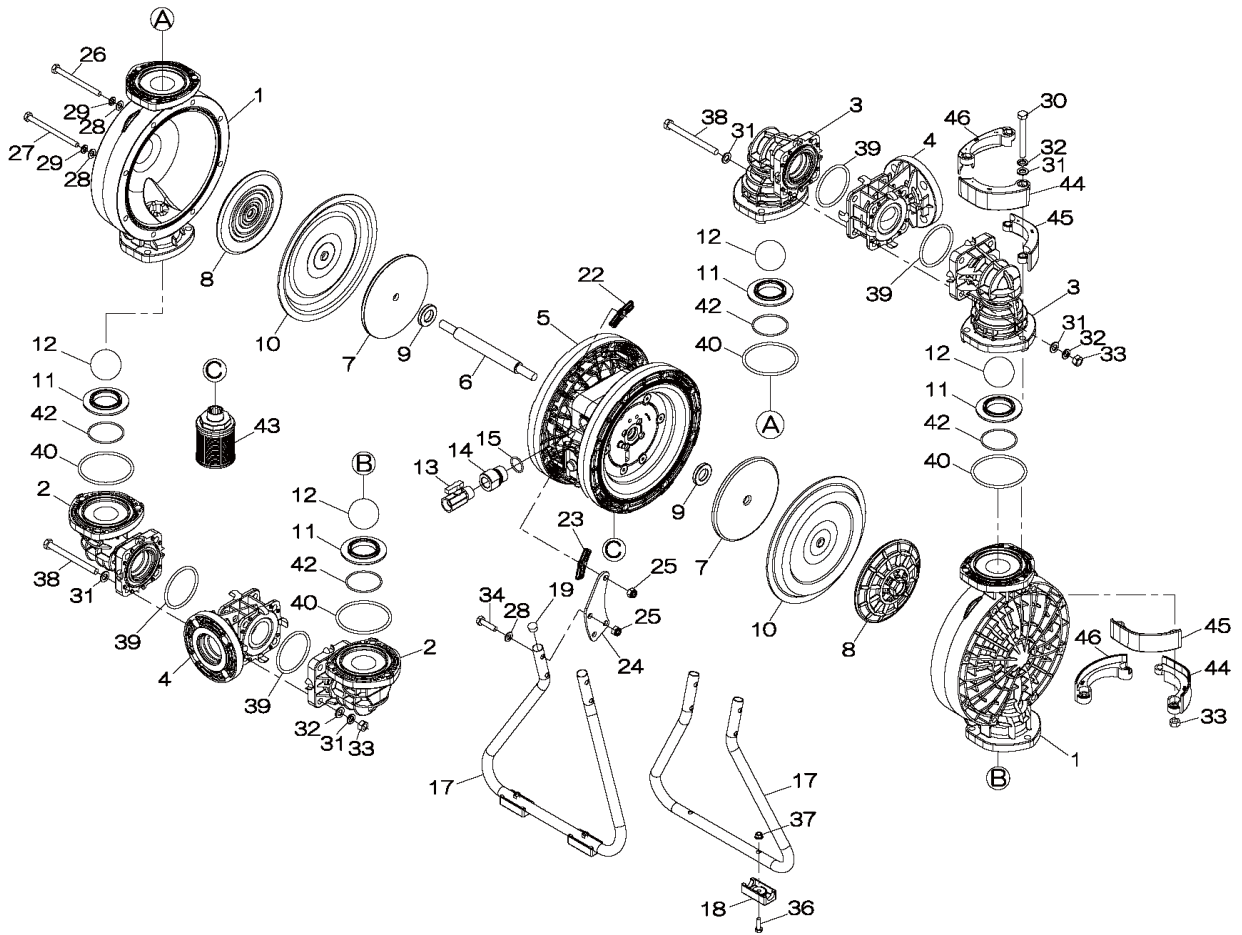

Air Operated Double Diaphragm Pump

805073 Center Body Assembly

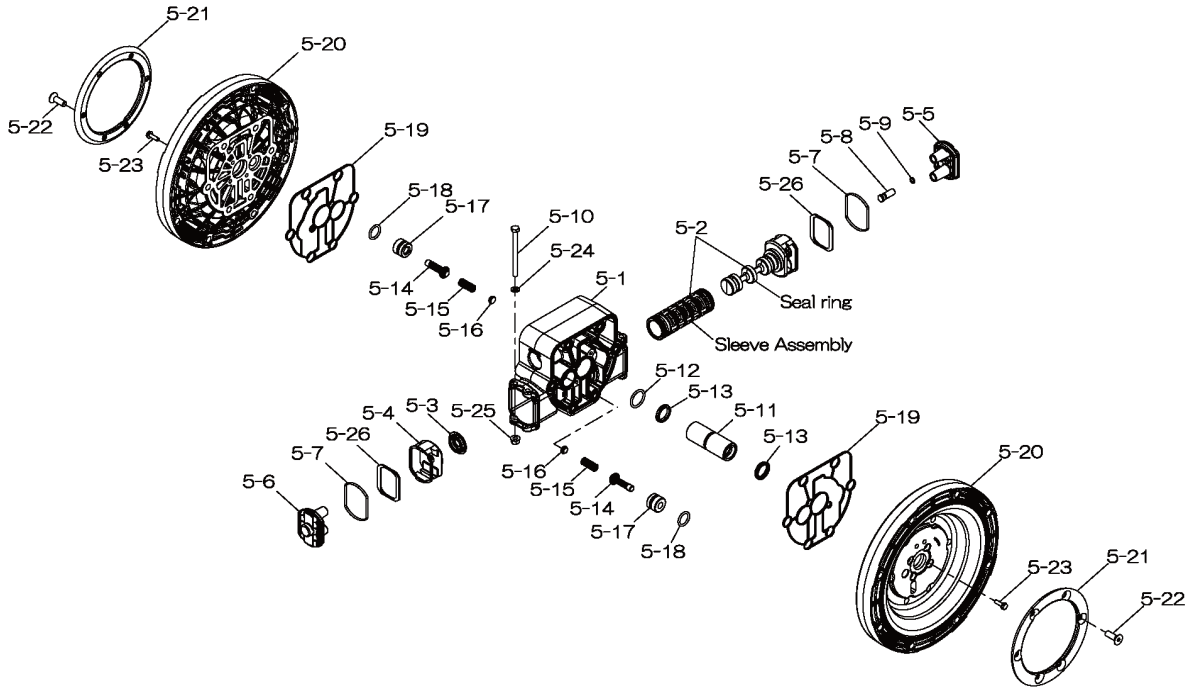

Air Operated Double Diaphragm Pump

	NDP-50BVE-PP	NDP-50BVV-PP	NDP-50BVH-PP	NDP-50BVS-PP			
REF. No.	PARTS No.	PARTS No.	PARTS No.	PARTS No.	DESCRIPTION	QTY.	REORDER
1	780153	780153	780153	780153	OUT CHAMBER 50PVDF-2	2	
2	780252	780252	780252	780252	IN MANIFOLD 50PVDF	2	
3	780154	780154	780154	780154	OUT MANIFOLD 50PVDF-2	2	
4	780115	780115	780115	780115	CENTER MANIFOLD 50PVDF	2	
5	805073	805073	805073	805073	CENTER BODY ASSY 50-PP	1	
5- 1	833121	833121	833121	833121	VALVE BODY ASSY (NPT)	1	
5- 2	805063	805063	805063	805063	C SPOOL ASSY (NDP-P)	1	
5- 3	771923	771923	771923	771923	CUSHION	1	
5- 4	771735	771735	771735	771735	SPRING RETAINER 40/50/	1	
5- 5	773249	773249	773249	773249	CAP A	1	
5- 6	773250	773250	773250	773250	CAP B	1	
5- 7	773252	773252	773252	773252	GASKET B	2	
5- 8	773259	773259	773259	773259	RESET BUTTON	1	
5- 9	640005	640005	640005	640005	O RING	1	
5-10	621167	621167	621167	621167	BOLT	4	
5-11	773253	773253	773253	773253	THROAT BEARING	1	
5-12	640027	640027	640027	640027	O RING	1	
5-13	685444	685444	685444	685444	V-PACKING	2	
5-14	832162	832162	832162	832162	PILOT VALVE ASSY	2	
5-15	711937	711937	711937	711937	PILOT VALVE SPRING	2	
5-16	773257	773257	773257	773257	SPRING SEAT	2	
5-17	773254	773254	773254	773254	VALVE SEAT	2	
5-18	640020	640020	640020	640020	O RING	2	
5-19	773251	773251	773251	773251	GASKET A	2	
5-20	780294	780294	780294	780294	AIR CHAMBER	2	
5-21	717073	717073	717073	717073	REINFORCING PLATE	2	
5-22	686748	686748	686748	686748	BOLT HEX.SOCKET	12	
5-23	686747	686747	686747	686747	TAPPING SCREW	8	
5-24	631173	631173	631173	631173	WASHER	4	
5-25	686783	686783	686783	686783	CUP NUT	4	
5-26	773334	773334	773334	773334	SPACER	2	
5-27	773258	773258	773258	773258	UNION	1	
5-28	640131	640131	640131	640131	O RING	1	
6	711900	711900	711900	711900	CENTER ROD 40/50	1	
7	711905	711905	711905	711905	CENTER DISK 50SS	2	
8	771727	771727	771727	771727	CENTER DISK 50PP-R	2	
9	770582	770582	770582	770582	CUSHION 40/50/80	2	
10	771856	771800	771703	771976	DIAPHRAGM 50	2	
11	772097	772097	772097	772097	VALVE SEAT 50PP-2	4	
12	770633	770636	773143	773173	BALL 50 -63MM	4	
13	684322	684322	684322	684322	BALL VALVE	1	
14	773258	773258	773258	773258	UNION	1	
15	640131	640131	640131	640131	O RING	1	
17	716885	716885	716885	716885	STAND 50-PP	2	
18	771865	771865	771865	771865	FOOT RUBBER	4	
19	683641	683641	683641	683641	CAP 40/50/80PP STAND	4	
22	716883	716883	716883	716883	SUPPORTING PLATE A 50-PP	8	

Air Operated Double Diaphragm Pump

	NDP-50BVE-PP	NDP-50BVV-PP	NDP-50BVH-PP	NDP-50BVS-PP			
REF. No.	PARTS No.	PARTS No.	PARTS No.	PARTS No.	DESCRIPTION	QTY.	REORDER
23	716884	716884	716884	716884	SUPPORTING PLATE B 50-PP	8	
24	716905	716905	716905	716905	CONNECTING PLATE 50-PP	4	
25	685185	685185	685185	685185	LOCK NUT	16	
26	686696	686696	686696	686696	BOLT	8	
27	686697	686697	686697	686697	BOLT	8	
28	631330	631330	631330	631330	WASHER FLAT	24	
29	680257	680257	680257	680257	SPRING WASHER	16	
30	621213	621213	621213	621213	BOLT	12	
31	631331	631331	631331	631331	WASHER M12 SS FLAT	28	
32	680607	680607	680607	680607	SPRING WASHER	20	
33	628014	628014	628014	628014	NUT	20	
34	621179	621179	621179	621179	BOLT	8	
36	621149	621149	621149	621149	BOLT	4	
37	683837	683837	683837	683837	NUT W/ FLANGE	4	
38	684592	684592	684592	684592	BOLT	8	
39	684121	642064	640064	684121	O RING 84.3MM X 5.7MM	4	
40	684122	642069	640069	684122	O RING 104.3MM X 5.7MM	4	
42	685448	642139	640139	685448	O RING 69MM X 3MM B70	4	
43	804764	804764	804764	804764	SILENCER ASSY.	1	
44	771786	771786	771786	771786	PROTECTOR A 50PP&PVDF	8	
45	771787	771787	771787	771787	PROTECTOR B 50PP&PVDF	8	
46	771788	771788	771788	771788	PROTECTOR C 50PP&PVDF	8	
KIT	K50-VE	K50-VV	K50-VH	K50-VS	LIQUID SIDE		
KIT	K50-AM-PP				AIR MOTOR		

General Tools:

- Socket wrench - 13mm, 17mm, 19mm
- Hexagonal box wrench - 6mm
- Small crowbars - 2 (B_C, B_N, B_E, B_V)
- Open-end wrenches - 19mm, 24mm
- Plastic hammer, Phillips head screw driver, adjustable angle wrenches, needle nose Pliers

Special Tools (sold separately):

- PP wrench (771866) to remove center disk
- Sleeve remover (713180) to remove sleeve

Miscellaneous:

- Assembly Oil—turbine oil none additional class 1 (equivalent to ISA VGA32 grade)
- Nuts - M16 x 1.5
- Thread locker
- Urea grease grade (NLGI) No. 2

Torque Requirements:

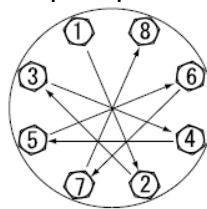

Tightening torque for center rod and out chambers.
 Center Rod 36 ft-lbf {50 N-m}
 Out Chambers 26 ft-lbf {35 N-m}

Tightening torque for manifold retainer bolts.
 BV_PP 18 ft-lbf {25 N-m}

Customer Notes

Model #: _____
 Description: _____
 Serial #: _____
 Date Installed: _____
 Department Location: _____
 Tag/Project: _____