

EXPLODED VIEW & PARTS LISTING

Air Operated Double Diaphragm Pump

Model: NDP-50BPT-PP

Part#: 854840



To Purchase:

☎ 800-990-7867

✉ sales@yamadapump.com

📍 Find My Rep

More Information:

▶ YouTube: @yamadapump

🌐 yamadapump.com

*Data Sheets | CAD Drawings | Manuals
Literature | BOM | Performance Curves*

Trial Program

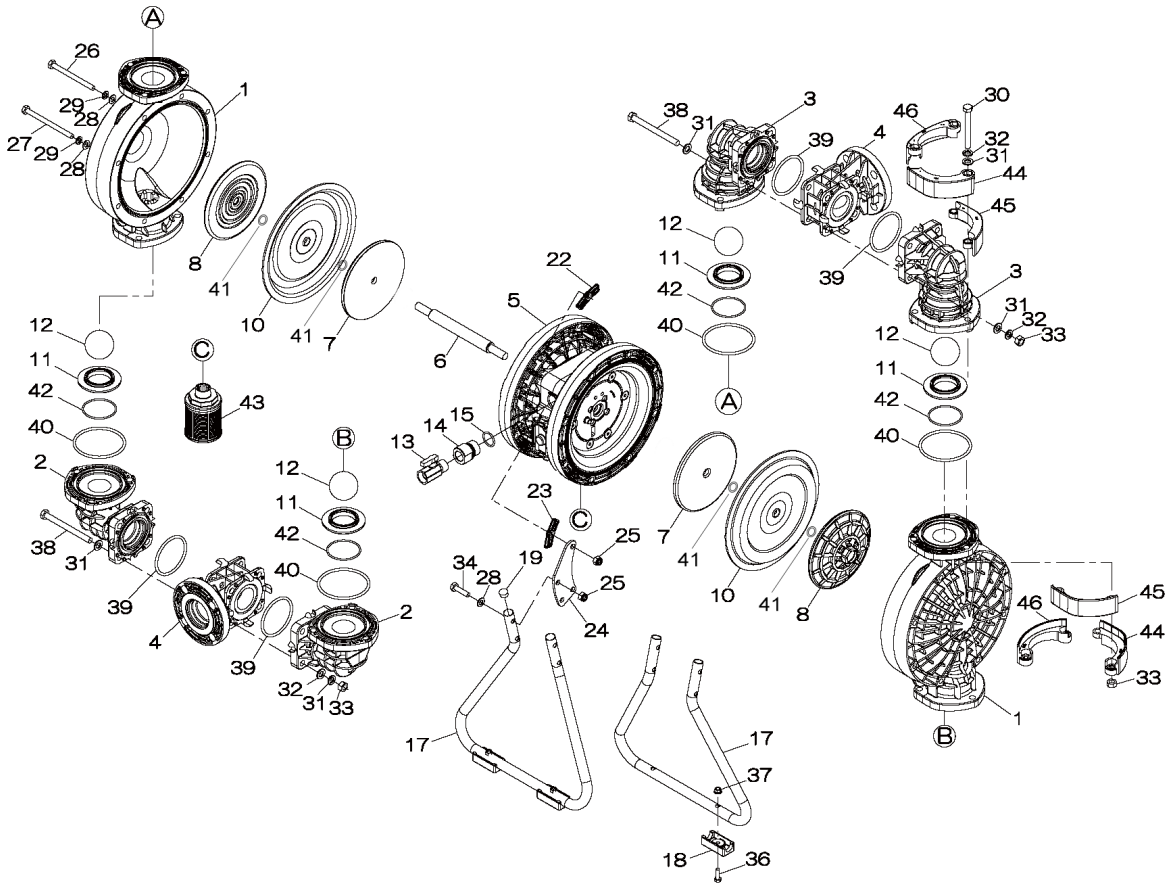

Air Operated Double Diaphragm Pump

805073 Center Body Assembly

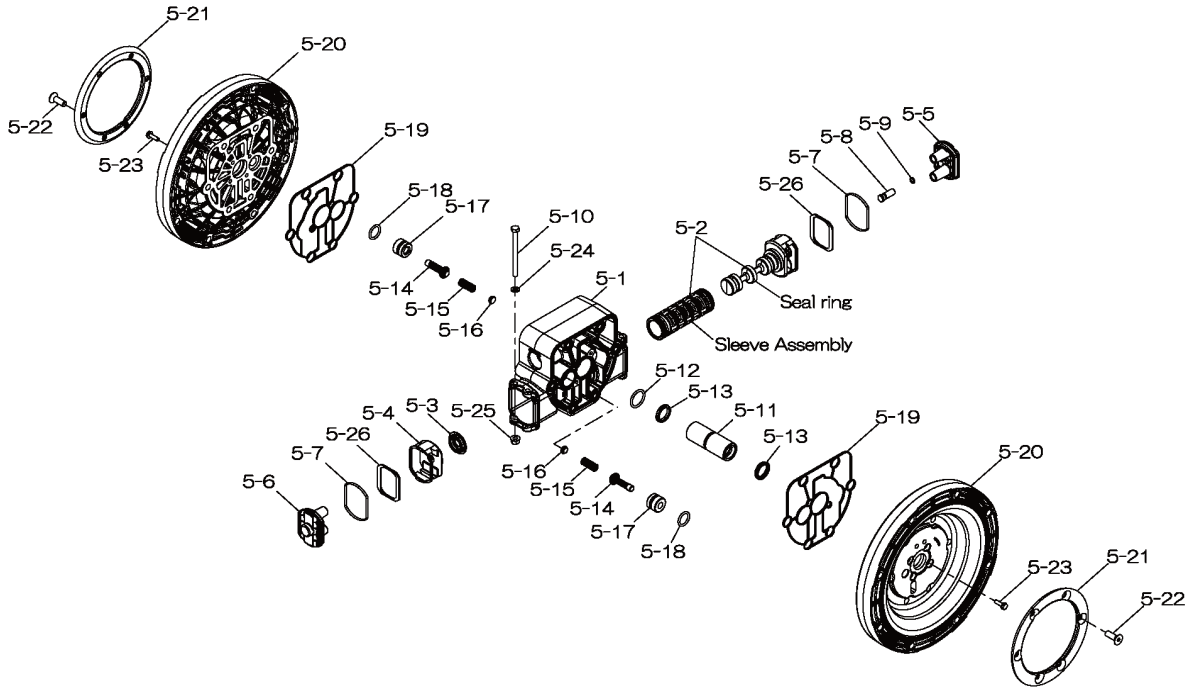

Air Operated Double Diaphragm Pump

REF. No.	PARTS No.	DESCRIPTION	QTY.	REORDER
1	780148	OUT CHAMBER 50PP-2	2	
2	780245	IN MANIFOLD 50PP	2	
3	780151	OUT MANIFOLD 50PP-2	2	
4	780249	CENTER MANIFOLD 50PP	2	
5	805073	CENTER BODY ASSY 50-PP	1	
5- 1	833121	VALVE BODY ASSY (NPT)	1	
5- 2	805063	C SPOOL ASSY (NDP-P)	1	
5- 3	771923	CUSHION	1	
5- 4	771735	SPRING RETAINER 40/50/	1	
5- 5	773249	CAP A	1	
5- 6	773250	CAP B	1	
5- 7	773252	GASKET B	2	
5- 8	773259	RESET BUTTON	1	
5- 9	640005	O RING	1	
5-10	621167	BOLT	4	
5-11	773253	THROAT BEARING	1	
5-12	640027	O RING	1	
5-13	685444	V-PACKING	2	
5-14	832162	PILOT VALVE ASSY	2	
5-15	711937	PILOT VALVE SPRING	2	
5-16	773257	SPRING SEAT	2	
5-17	773254	VALVE SEAT	2	
5-18	640020	O RING	2	
5-19	773251	GASKET A	2	
5-20	780294	AIR CHAMBER	2	
5-21	717073	REINFORCING PLATE	2	
5-22	686748	BOLT HEX.SOCKET	12	
5-23	686747	TAPPING SCREW	8	
5-24	631173	WASHER	4	
5-25	686783	CUP NUT	4	
5-26	773334	SPACER	2	
5-27	773258	UNION	1	
5-28	640131	O RING	1	

REF. No.	PARTS No.	DESCRIPTION	QTY.	REORDER
6	711939	CENTER ROD 40/50T	1	
7	707823	CENTER DISK 50SS-T OUTER	2	
8	780063	CENTER DISK 50PP-T	2	
10	770815	DIAPHRAGM 50T	2	
11	772097	VALVE SEAT 50PP-2	4	
12	770693	BALL 50T	4	
13	684322	BALL VALVE	1	
17	716885	STAND 50-PP	2	
18	771865	FOOT RUBBER	4	
19	683641	CAP 40/50/80PP STAND	4	
22	716883	SUPPORTING PLATE A 50-PP	8	
23	716884	SUPPORTING PLATE B 50-PP	8	
24	716905	CONNECTING PLATE 50-PP	4	
25	685185	LOCK NUT	16	
26	686696	BOLT	8	
27	686697	BOLT	8	
28	631330	WASHER FLAT	24	
29	680257	SPRING WASHER	16	
30	621213	BOLT	12	
31	631331	WASHER M12 SS FLAT	28	
32	680607	SPRING WASHER	20	
33	628014	NUT	20	
34	621179	BOLT	8	
36	621149	BOLT	4	
37	683837	NUT W/ FLANGE	4	
38	684592	BOLT	8	
39	643064	O RING	4	
40	643069	O RING	4	
41	643015	O RING	4	
42	643139	O RING	4	
43	804764	SILENCER ASSY.	1	
44	771786	PROTECTOR A 50PP&PVDF	8	
45	771787	PROTECTOR B 50PP&PVDF	8	
46	771788	PROTECTOR C 50PP&PVDF	8	
Kits				REORDER
K50-PT Liquid Side Kit				
K50-AM-PP Air Side Kit				

General Tools:

- Socket wrench - 13mm, 17mm, 19mm
- Hexagonal box wrench - 6mm
- Open-end wrenches - 19mm, 24mm
- Plastic hammer
- Phillips head screw driver
- Adjustable angle wrenches
- Needle nose pliers

Special Tools:

- PP wrench (771868) for removing the center disk
- Sleeve remover (713180) to removing sleeve (sold separately)

Miscellaneous:

- Assembly Oil - Turbine oil none additional class 1 (equivalent to ISA VGA32 grade)
- Nuts - M16 x 1.5
- Thread locker
- Urea grease grade (NLGI) No. 2

Torque Requirements:

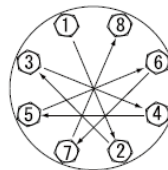

Tightening torque for center rod and out chambers.

- Center Rod 36 ft-lbf {50 N-m}
- Out Chambers 26 ft-lbf {35 N-m}

Tightening torque for manifold retainer bolts.

- BPT 15 ft-lbf {20 N-m}

Customer Notes

Model #: _____

Description: _____

Serial #: _____

Date Installed: _____

Department Location: _____

Tag/Project: _____