

Air Operated Double Diaphragm Pump

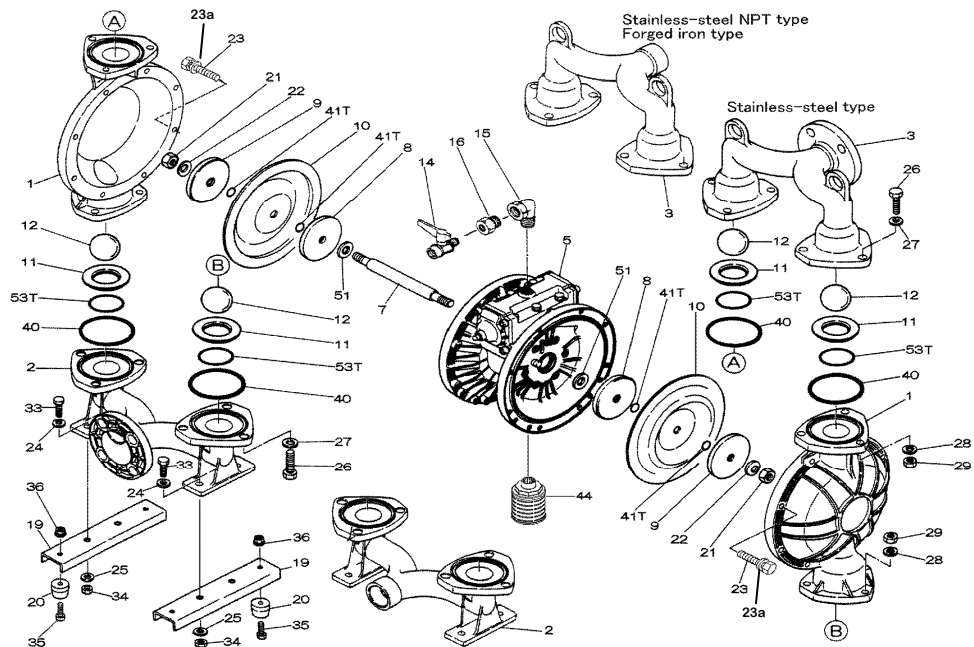

Parts List

Ref. No.	Description	Qty	Part No.
1	Out Chamber	2	713157
2	In Manifold - NPT	1	713169
3	Out Manifold - NPT	1	713166
5	Body Assembly	1	803112
7	Center Rod	1	711939
8	Center Disk	2	707822
9	Center Disk	2	713370
10	Diaphragm	2	770815
11	Valve Seat	4	711909
12	Ball	4	770693
14	Ball Valve	1	684322
15	Elbow	1	682523
19	Pump Base	2	711928
20	Cushion	4	771402
21	Nut	2	706128
22	Coned Disk Spring	2	682740
23	Bolt	16	686160
23a	Wave Spring Washer	16	631917
24	Plain Washer	4	631014
25	Wave Spring Washer	4	631917
26	Bolt	12	611202
27	Plain Washer	12	631015
28	Spring Lock Washer	12	631918
29	Nut	12	627014
33	Bolt	4	611175
34	Nut	4	627013
35	Bolt	4	611149
36	Nut with Flange	4	682276
40	O-ring	4	643069
41T	O-ring	4	643015
44	Muffler	1	804764
51	Cushion	2	770582
53T	O-ring	4	643139

Repair Kits

K50-MT Liquid Side Kit includes the following:

Ref. No.	Description	Qty	Part No.
10	Diaphragm	2	770815
12	Ball	4	770693
40	O-ring	4	643069
53T	O-ring	4	643139
41T	O-ring	4	643015

K45-AM Air Side Kit includes the following:

Ref. No.	Description	Qty	Part No.
5-3	Throat Bearing	2	772689
5-4	Spring	2	711937
5-5	Valve Seat	2	771740
5-6	Pilot Valve Assembly	2	832162
5-8	O-ring	2	640020
5-9	Packing	2	685444
5-10	O-ring	2	640029
5-11	Gasket	2	771742
5-14	Gasket	1	771712
5-13-8	Gasket	2	771738
5-13-12	C-Spool Assy (CF)	1	805084

Air Operated Double Diaphragm Pump

803112 Body Assembly

Ref. No.	Description	Qty	Part No.
5-1	Air Chamber	2	711934
5-2	Body	1	711936
5-3	Throat Bearing	2	772689
5-4	Spring	2	711937
5-5	Valve Seat	2	771740
5-6	Pilot Valve Assembly	2	832162
5-8	O-ring	2	640020
5-9	Packing	2	685444
5-10	O-ring	2	640029
5-11	Gasket	2	771742
5-12	Flat Head Bolt	12	683812
5-13	Valve Body Assembly	1	802971
5-14	Gasket	1	771712
5-15	Bolt	6	684240
5-18	Plain Washer	12	684987

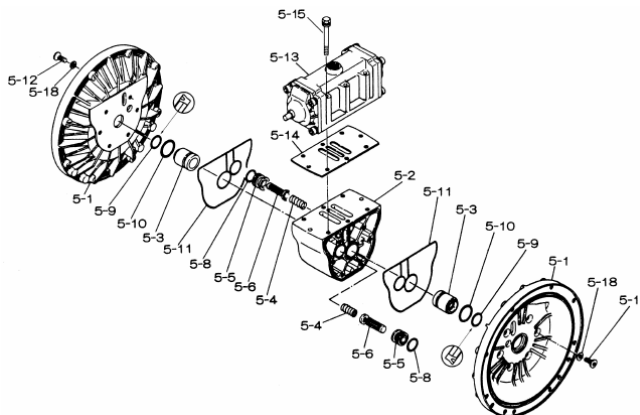

802971 Air Valve Body Assembly

Ref. No.	Description	Qty	Part No.
5-13-1	Valve Body	1	711931
5-13-2	Cap A	1	580999
5-13-3	Cap B	1	581000
5-13-5	Spring Stopper	1	771735
5-13-6	Reset Button	1	712976
5-13-8	Gasket	2	771738
5-13-9	Bolt	8	685036
5-13-12	C-Spool Assy (CF)	1	805084
5-13-12 *1 Sleeve	Sleeve Assembly	1	803675
5-13-13	O-ring	1	640005
5-13-14	Cushion	4	684128



805084 C-Spool Assembly (CF)

Ref. No.	Description	Qty	Part No.
A	Sleeve Assy.	1	803675
B	O-ring (sleeve)	6	640036
C	Spool Assy (CF)	1	805085
D	Spring Retainer	1	771735
E	C-Spring	2	711932
F	Block	1	771734

