

EXPLODED VIEW & PARTS LISTING

Air Operated Double Diaphragm Pump

Model: NDP-25BVT
Model #: 852219 - NPT
Model #: 853858 - Flange
w/metal center body

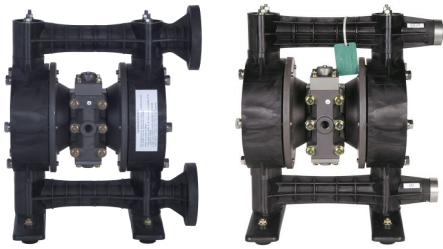

To Purchase:

- 800-990-7867
- sales@yamadapump.com
- Find My Rep

More Information:

- YouTube: @yamadapump
- yamadapump.com
- Data Sheets | CAD Drawings | Manuals Literature | BOM | Performance Curves

Trial Program

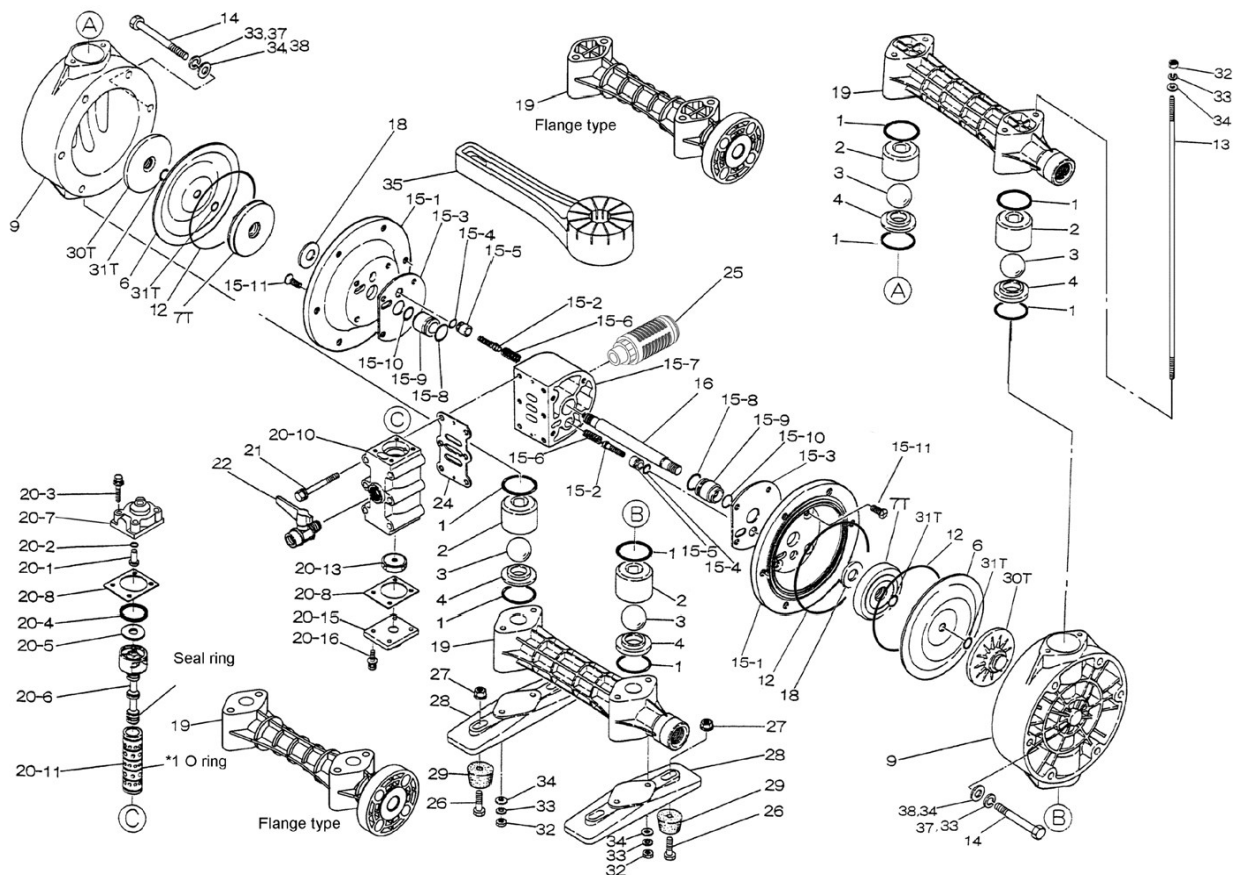

EXPLODED VIEW & PARTS LISTING

Model: NDP-25BVT
Model #: 852219 - NPT
Model #: 853858 - Flange
w/metal center body



Air Operated Double Diaphragm Pump

REF.NO.	PART NO.	DESCRIPTION	QTY	REORDER
1	643042	O-RING	4	
2	773419	BALL GUIDE 25VN	4	
3	770691	BALL 25T -35MM PTFE	4	
4	780317	VALVE SEAT 25VN	4	
5T	643041	O-RING	4	
6	771110	DIAPHRAGM (PTFE) 25	2	
7T	709459	CENTER DISK 25T (INNER)	2	
9	780312	OUT CHAMBER 25VN	2	
12	640154	O-RING	2	
13	710207	TIE ROD 25PP	4	
14	621189	BOLT	12	
15	804881	BODY	1	
15- 1	715940	AIR CHAMBER	2	
15- 2	802360	PILOT VALVE ASSY	2	
15- 3	771057	GASKET	2	
15- 4	640009	O-RING	2	
15- 5	771945	PILOT VALVE SEAT	2	
15- 6	708666	SPRING	2	
15- 7	711503	BODY	1	
15- 8	685276	O-RING	2	
15- 9	772703	THROAT BEARING	2	
15-10	685414	V-PACKING	2	
15-11	682486	BOLT FLAT HD W/ WASHER	8	
16	710271	CENTER ROD	1	
18	771054	CUSHION	2	
19	780314	MANIFOLD 25VN - NPT	2	
19	780316	MANIFOLD 25VN - FLANGE	2	
20	802809	VALVE BODY ASSY.	1	
20- 1	709161	RESET BUTTON	1	
20- 2	640005	O-RING	1	
20- 3	682704	BOLT M6 FT ZINC W/ WAS	4	
20- 4	771241	PACKING	1	
20- 5	715961	WASHER	1	
20- 6	802400	C SPOOL ASSY	1	
20-6 seal	771053	SEAL RING	5	
20- 7	711219	CAP A 20/25PP	1	
20- 8	771240	GASKET 20/25	2	
20-10	711640	VALVE BODY	1	
20-11	803931	SLEEVE ASSY	1	
20-11-*1	771080	O-RING	6	
20-13	771914	CUSHION	1	
20-15	711212	CAP B 20/25PP	1	
20-16	682262	BOLT M6 FT ZINC W/ WAS	4	

REF.NO.	PART NO.	DESCRIPTION	QTY	REORDER
21	682265	BOLT M8 PT ZINC W/ WAS	6	
22	686970	BALL VALVE	1	
24	771056	GASKET	1	
25	804697	MUFFLER	1	
26	611153	BOLT	4	
27	682276	NUT W/FLANGE	4	
28	771749	BASE 25V	2	
29	770551	FOOT RUBBER	4	
30T	780319	CENTER DISK 25V-PTFE (OUTER)	2	
31T	643013	O-RING	4	
32	683635	NUT	8	
33	681300	SPRING WASHER	8	
34	631329	FLAT WASHER	8	
35	771244	TOOL	2	
37	680257	SPRING WASHER	12	
38	631330	FLAT WASHER	12	
KIT	K25-VT	LIQUID END KIT		
KIT	K225-AM	AIR MOTOR KIT		

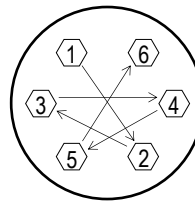

Tightening torque for center rod and out chambers.

Center Rod 29 ft-lbf {40 N-m}
 Out Chambers 15 ft-lbf {20 N-m}

Tightening torque for manifold retainer nuts.

BVT 10 ft-lbf {12 N-m}

General Tools:

- Socket wrenches - 10mm, 12mm, 13mm, 17mm, 22mm
- Hexagonal box wrench - 5mm
- Open-end wrench - 13mm

Special Tools:

- Accessory tool (771244) to remove the center disk (included).
- Sleeve remover (713148) (sold separately).

Miscellaneous:

- Assembly Oil - turbine oil none additional class 1 (equivalent to ISO VG32 grade)
- Nuts - M14 x 1.5
- Urea grease grade (NLGI) No. 2
- Lubricants - equivalent to Loctite anti-seize 767

Customer Notes

Model #: _____
 Description: _____
 Serial #: _____
 Date Installed: _____
 Department Location: _____
 Tag/Project: _____