

# EXPLODED VIEW & PARTS LISTING

## Air Operated Double Diaphragm Pump

Model: NDP-25BVT-PN

Part# 854958 - NPT

Part# 854968 - Flange

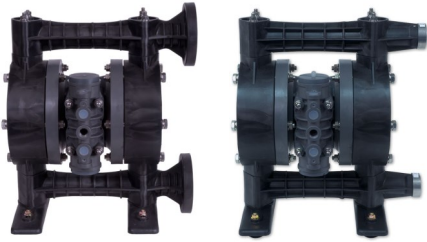

### To Purchase:

☎ 800-990-7867

✉ sales@yamadapump.com

📍 Find My Rep

### More Information:

▶ YouTube: @yamadapump

🌐 yamadapump.com

Data Sheets | CAD Drawings | Manuals Literature | BOM | Performance Curves

### Trial Program

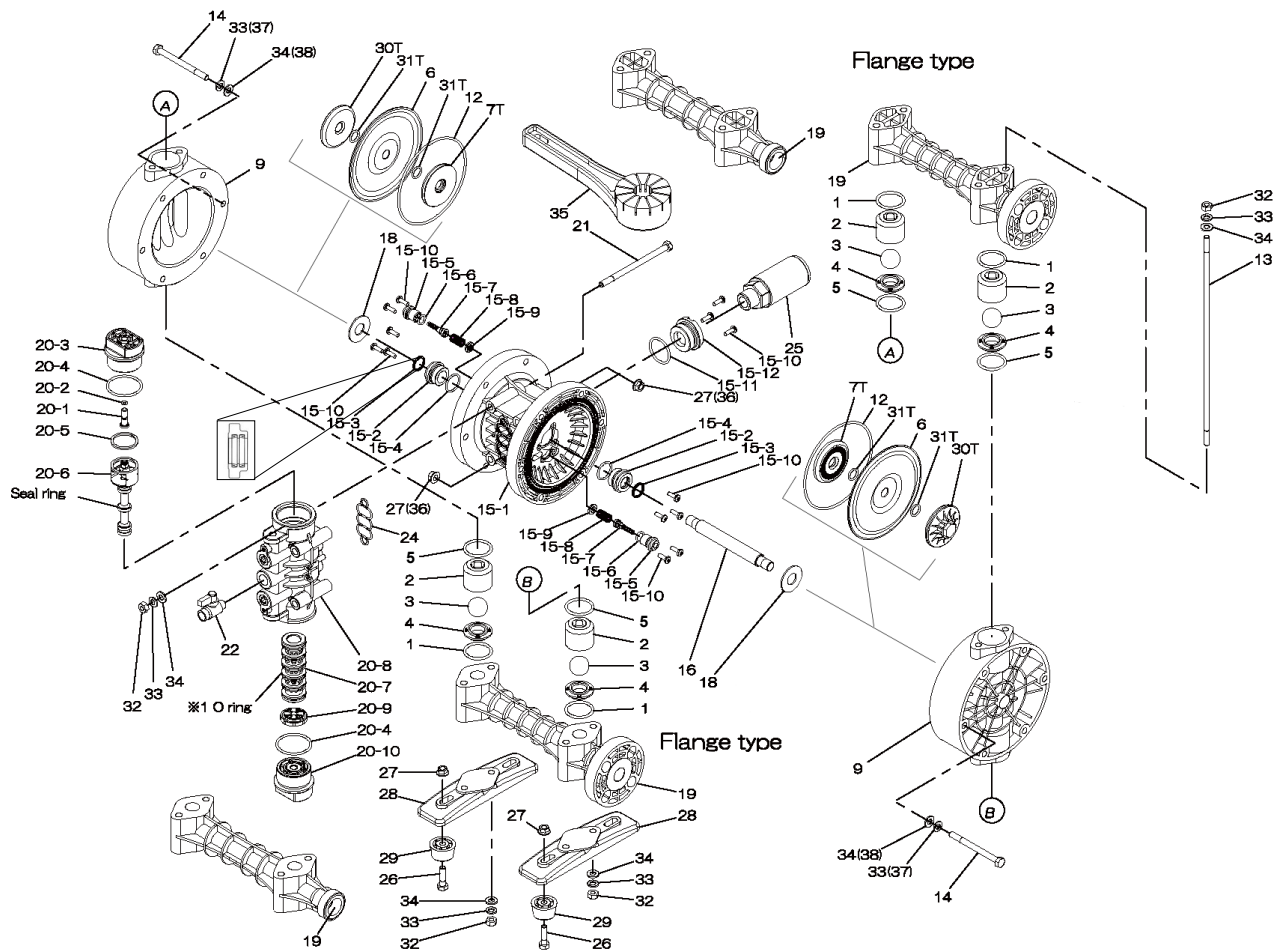

REF.NO.	PART NO.	DESCRIPTION	QTY	REORDER
NPT	854958	** NPT **		
Flange	854968	** Flange **		
1	643042	O-RING	4	
2	773419	BALL GUIDE 25PVDF	4	
3	770691	BALL 25T PTFE	4	
4	780317	BALL SEAT 25PVDF	4	
5	643041	O-RING	4	
6	771110	DIAPHRAGM (PTFE) 25	2	
7T	709459	CENTER DISK 25T (air side)	2	
9	780312	OUT CHAMBER 25PVDF	2	
12	640154	O-RING	2	
13	710207	TIE ROD 25PP	4	
14	683541	BOLT	12	
15	804604	BODY ASSY	1	
15- 1	772929	BODY 25-PP	1	
15- 2	772931	THROAT BEARING 20/25-PP	2	
15- 3	685414	V-PACKING 20/25	2	
15- 4	685276	O-RING	2	
15- 5	772932	VALVE SEAT 20/25-PP	2	
15- 6	640009	O-RING	2	
15- 7	802360	PILOT VALVE ASSY 20/25	2	
15- 8	708666	SPRING 20/25	2	
15- 9	772948	SPRING SEAT 20/25-PP	2	
15-10	686030	TAPPING SCREW	13	
15-11	640132	O-RING	1	
15-12	772933	BUSHING 20/25-PP	1	
16	710271	CENTER ROD 25P&V	1	
18	771054	CUSHION 20/25	2	
19	780314	MANIFOLD 25PVDF-NPT	2	
19	780316	MANIFOLD 25PVDF-FLANGE	2	
20	804608	VALVE BODY ASSY	1	
20- 1	772991	RESET BUTTON 20/25-PP	1	
20- 2	640002	O-RING	1	
20- 3	772946	CAP A 20/25-PP	1	
20- 4	640043	O-RING	2	
20- 5	771241	PACKING 20/25	1	
20- 6	802400	C SPOOL ASSY	1	
20-6-seal	771053	SEAL RING	5	
20- 7	804609	SLEEVE ASSY	1	
20-7-*1	686029	O-RING	6	
20- 8	832903	VALVE BODY 20/25-PP	1	
20- 9	771914	CUSHION 20/25	1	
20-10	772947	CAP B 20/25-PP	1	
21	686031	BOLT	4	
22	686970	BALL VALVE 25&25F 3/8	1	
24	772848	GASKET 20/25-PP	1	
25	804697	MUFFLER 20/25PP	1	
26	621153	BOLT M8	4	
27	686032	NUT W/FLANGE	4	
28	771749	BASE 25V	2	
29	770551	FOOT RUBBER 15PP,20/25	4	
30T	780319	CENTER DISK 25V-PTFE (liquid side)	2	
31T	643013	O-RING	4	
32	683635	NUT	12	
33	681300	SPRING WASHER	12	
34	631329	WASHER FLAT	12	
35	771244	TOOL 20/25PP&V	2	
36	686033	NUT W/FLANGE	12	
37	680257	SPRING WASHER	12	
38	631330	WASHER FLAT	12	
KIT	K25-VT-PP	LIQUID END KIT		
KIT	K225-AP	AIR MOTOR KIT		

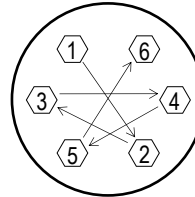

**Tightening torque for center rod and out chambers.**

Center Rod 29 ft-lbf {40 N-m}  
 Out Chambers 15 ft-lbf {20 N-m}

**Tightening torque for manifold retainer nuts.**

BVT-PN 9 ft-lbf {12 N-m}

**General Tools:**

- Socket wrenches - 10mm, 12mm, 13mm, 17mm, 22mm
- Hexagonal box wrench - 5mm
- Open-end wrenches - 12mm, 13mm, 22mm
- Adjustable angle wrenches
- Phillips head screw driver

**Special Tools:**

- Accessory tool (2) 771244 (included) to remove the center disk.
- Sleeve remover 713148 (sold separately) used for removing the sleeve.

**Miscellaneous:**

- Assembly Oil - turbine oil none additional class 1 (equivalent to ISO VG32 grade)
- Nuts - M14 x 1.5
- Urea grease grade (NLGI) No. 2

**Customer Notes**

Model #: \_\_\_\_\_  
 Description: \_\_\_\_\_  
 Serial #: \_\_\_\_\_  
 Date Installed: \_\_\_\_\_  
 Department Location: \_\_\_\_\_  
 Tag/Project: \_\_\_\_\_