

EXPLODED VIEW & PARTS LISTING

Air Operated Double Diaphragm Pump

Model: NDP-20BPT
 Model#: 851666 (NPT)
 Model#: 853832 (Flange)

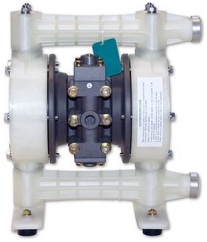

Flange Manifold

To Purchase:

- 800-990-7867
- sales@yamadapump.com
- Find My Rep

More Information:

- YouTube: @yamadapump
- yamadapump.com
- Data Sheets | CAD Drawings | Manuals Literature | BOM | Performance Curves

Trial Program

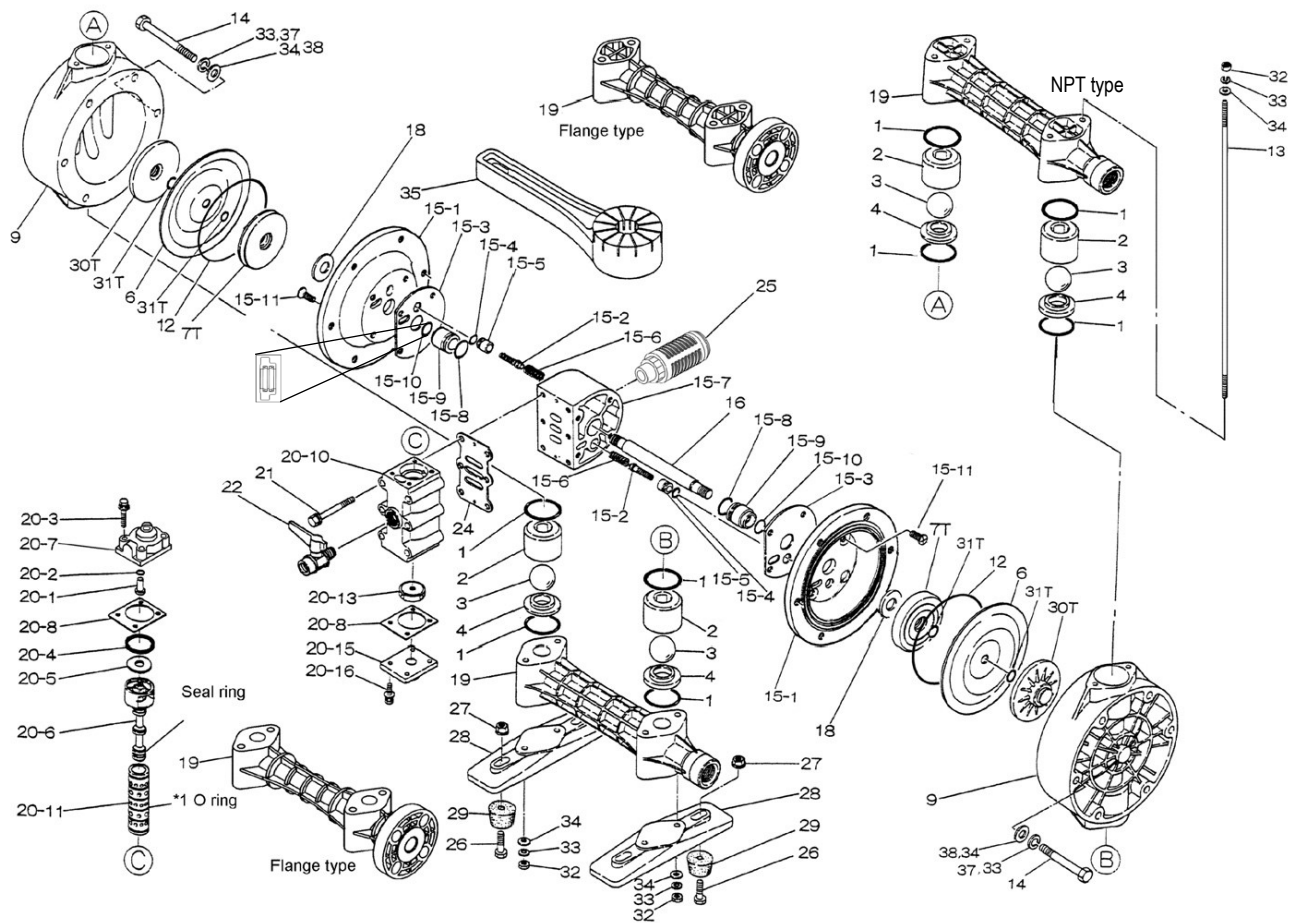

EXPLODED VIEW & PARTS LISTING

Air Operated Double Diaphragm Pump

Model: NDP-20BPT
 Model#: 851666 (NPT)
 Model#: 853832 (Flange)



REF. No.	PARTS No.	DESCRIPTION	QTY.	REORDER
NPT	851666	** NPT PUMPS **		
FLANGE	853832	** FLANGE PUMPS **		
1	643033	O-RING	8	
2	771216	BALL GUIDE	4	
3	770736	BALL	4	
4	780137	VALVE SEAT	4	
6	771083	DIAPHRAGM	2	
7T	709456	CENTER DISK (AIR SIDE)	2	
9	780134	OUT CHAMBER	2	
12	640151	O-RING	2	
13	710122	TIE ROD	4	
14	621163	BOLT	12	
15	804878	CENTER BODY ASSY.	1	
15-1	715938	AIR CHAMBER	2	
15-2	802360	PILOT VALVE ASSY.	2	
15-3	771057	GASKET	2	
15-4	640009	O-RING	2	
15-5	771945	PILOT VALVE SEAT	2	
15-6	708666	SPRING	2	
15-7	711503	BODY	1	
15-8	685276	O-RING	2	
15-9	780324	THROAT BEARING	2	
15-10	685414	V-PACKING	2	
15-11	682486	BOLT	8	
16	710252	CENTER ROD	1	
18	771054	CUSHION	2	
19	780010	MANIFOLD (NPT)	2	
19	780208	MANIFOLD (FLANGE)	2	
20	802809	AIR VALVE ASSY.	1	
20-1	709161	RESET BUTTON	1	
20-2	640005	O-RING	1	
20-3	682704	BOLT	4	
20-4	771241	PACKING	1	
20-5	715961	WASHER	1	
20-6	802400	C-SPOOL ASSY.	1	
20-6-seal	771053	SEAL RING	5	
20-7	711219	CAP A	1	
20-8	771240	GASKET	2	
20-10	711640	VALVE BODY	1	
20-11	803931	SLEEVE ASSY.	1	
20-11-*1	771080	O-RING	6	
20-13	771914	CUSHION	1	
20-15	711212	CAP B	1	
20-16	682262	BOLT	4	
21	682265	BOLT	6	
22	686968	BALL VALVE	1	
24	771056	GASKET	1	
25	804697	MUFFLER	1	
26	611151	BOLT	4	
27	682276	NUT W/FLANGE	4	
28	771219	BASE	2	
29	770551	FOOT RUBBER	4	
30T	780124	CENTER DISK (LIQUID SIDE)	2	
31T	643013	O-RING	4	
32	683635	NUT	8	
33	681300	SPRING WASHER	20	
34	631329	FLAT WASHER	20	
35	771244	TOOL	2	
KIT	K20-PT	LIQUID SIDE		
KIT	K225-AM	AIR MOTOR		

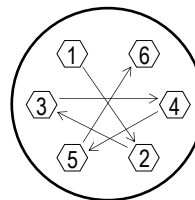

Tightening torque for center rod and out chambers.

Center Rod 29 ft-lbf {40 N-m}
 Out Chambers 10 ft-lbf {13 N-m}

Tightening torque for manifold retainer nuts.

BPT 10 ft-lbf {12 N-m}

General Tools:

- Socket wrenches - 10mm, 12mm, 13mm, 17mm, 22mm
- Hexagonal box wrench - 5mm
- Open-end wrenches - 13mm

Special Tools:

- Disc remover (771244) (included)
- Sleeve remover (713148) (sold separately)

Miscellaneous:

- Assembly Oil - turbine oil class 1 (equivalent to ISO VG32 grade)
- Nuts - M14 x 1.5
- Urea grease grade (NLGI) No. 2
- Lubricants equivalent to (Loctite Anti-Seize 767)

Customer Notes

Model #: _____

Description: _____

Serial #: _____

Date Installed: _____

Department Location: _____

Tag/Project: _____