

# EXPLODED VIEW & PARTS LISTING

## Air Operated Double Diaphragm Pump

Model: NDP-20BAT

Model#: 851518



### To Purchase:

☎ 800-990-7867

✉ sales@yamadapump.com

📍 Find My Rep

### More Information:

▶ YouTube: @yamadapump

🌐 yamadapump.com

Data Sheets | CAD Drawings | Manuals Literature | BOM | Performance Curves

Note: starting serial # 487505

### Trial Program

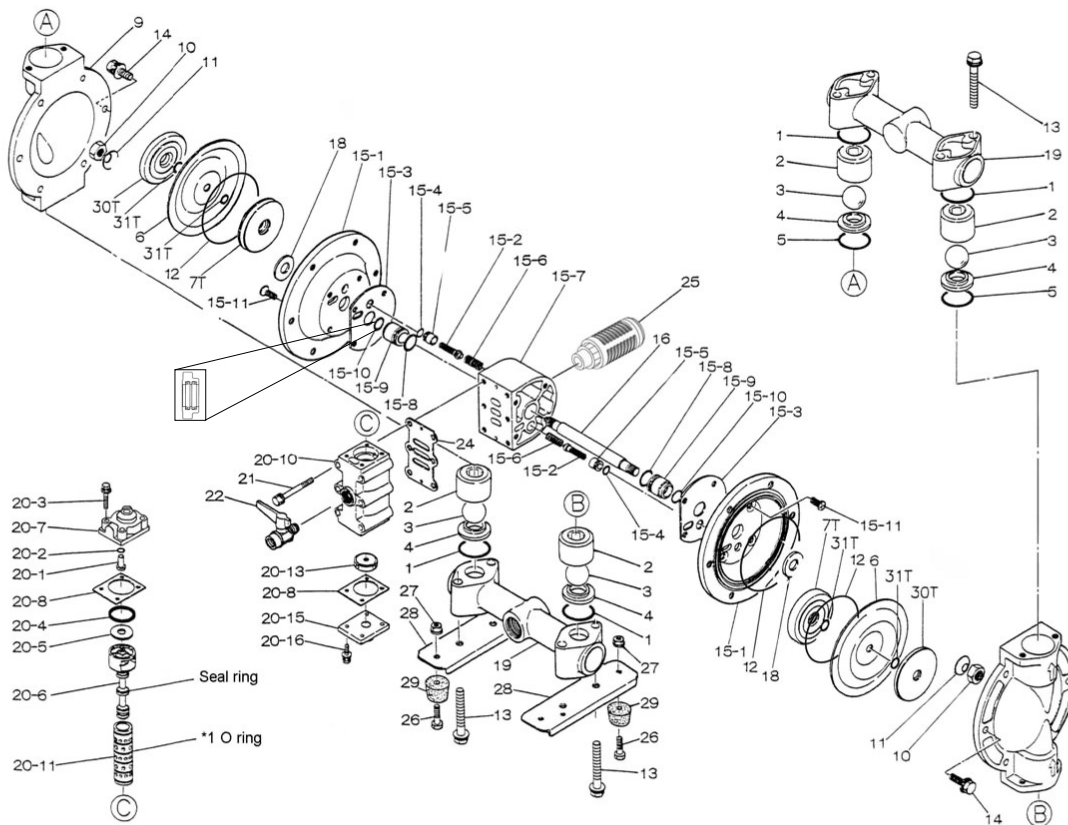

Air Operated Double Diaphragm Pump

REF. No.	PART No.	DESCRIPTION	QTY.	REORDER
1	643036	O-RING	4	
2	711700	BALL GUIDE	4	
3	770736	BALL	4	
4	590086	VALVE SEAT	4	
5	771131	O-RING	2	
6	771083	DIAPHRAGM	2	
7T	709456	CENTER DISK	2	
9	711686	OUT CHAMBER	2	
10	682263	NUT	2	
11	682730	CONED DISK SPRING	2	
12	640151	O-RING	2	
13	682264	BOLT	8	
14	682724	BOLT	12	
15	804878	BODY ASSY.	1	
15-1	715937	AIR CHAMBER	2	
15-2	802360	PILOT VALVE ASSY.	2	
15-3	771057	GASKET	2	
15-4	640009	O-RING	2	
15-5	771945	VALVE SEAT	2	
15-6	708666	SRING	2	
15-7	709812	BODY	1	
15-8	685276	O-RING	2	
15-9	780324	THROAT BEARING	2	
15-10	685414	V-PACKING	2	
15-11	682486	FLAT HEAD BOLT	8	
16	709163	CENTER ROD	1	
18	771054	CUSHION	2	
19	831280	MANIFOLD	2	
20	802362	VALVE BODY ASSY.	1	
20-1	709161	RESET BUTTON	1	
20-2	640005	O-RING	1	
20-3	682704	BOLT	4	
20-4	771241	PACKING	1	
20-5	715961	PLAIN WASHER	1	
20-6	802400	C-SPOOL VALVE ASSY.	1	
20-6-seal	771053	SEAL RING	5	
20-7	710221	CAP A	1	
20-8	771240	GASKET	2	
20-10	711639	VALVE BODY	1	
20-11	803931	SLEEVE ASSY.	1	
20-11-*1	771080	O-RING	6	
20-13	771914	CUSHION	1	
20-15	709305	CAP B	1	
20-16	682262	BOLT	4	
21	682265	BOLT	6	
22	686968	BALL VALVE	1	
24	771056	GASKET	1	
25	804697	SILENCER	1	
26	611148	BOLT	4	
27	682276	NUT W/FLANGE	4	
28	709157	PUMP BASE	2	
29	770551	CUSHION	4	
30T	709314	CENTER DISK (OUTER)	2	
31T	643013	O-RING	4	
KIT	K20-MT-1	LIQUID SIDE KIT		
KIT	K225-AM	AIR MOTOR KIT		

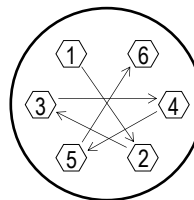

**Tightening torque for center rod and out chambers.**

Center Rod 29 ft-lbf {40 N-m}  
Out Chambers 10 ft-lbf {13 N-m}

**Tightening torque for manifold retainer bolts.**

BAT 15 ft-lbf {20 N-m}

**General Tools:**

- Socket wrenches - 10mm, 12mm, 13mm, 17mm, 22mm
- Hexagonal box wrench - 5mm
- Open-end wrenches - 22mm

**Special Tools:**

- Sleeve remover (713148) used for removing the sleeve.

**Miscellaneous:**

- Assembly Oil - turbine oil none additional class 1 (equivalent to ISA VGA32 grade)
- Nuts - M14 x 1.5
- Urea grease grade (NLGI) No. 2
- Lubricants equivalent to (Loctite Anti-Seize 767)

Customer Notes	
Model #:	_____
Description:	_____
Serial #:	_____
Date Installed:	_____
Department Location:	_____
Tag/Project:	_____