

# EXPLODED VIEW & PARTS LISTING

## Air Operated Double Diaphragm Pump

Model: DP-38F Ball Valve  
High Purity Pump  
853705 DP-38F Flange



### To Purchase:

☎ 800-990-7867

✉ [sales@yamadapump.com](mailto:sales@yamadapump.com)

📍 [Find My Rep](#)

### More Information:

▶ YouTube: [@yamadapump](#)

🌐 [yamadapump.com](http://yamadapump.com)

[Data Sheets](#) | [CAD Drawings](#) | [Manuals](#)  
[Literature](#) | [BOM](#) | [Performance Curves](#)

### Trial Program

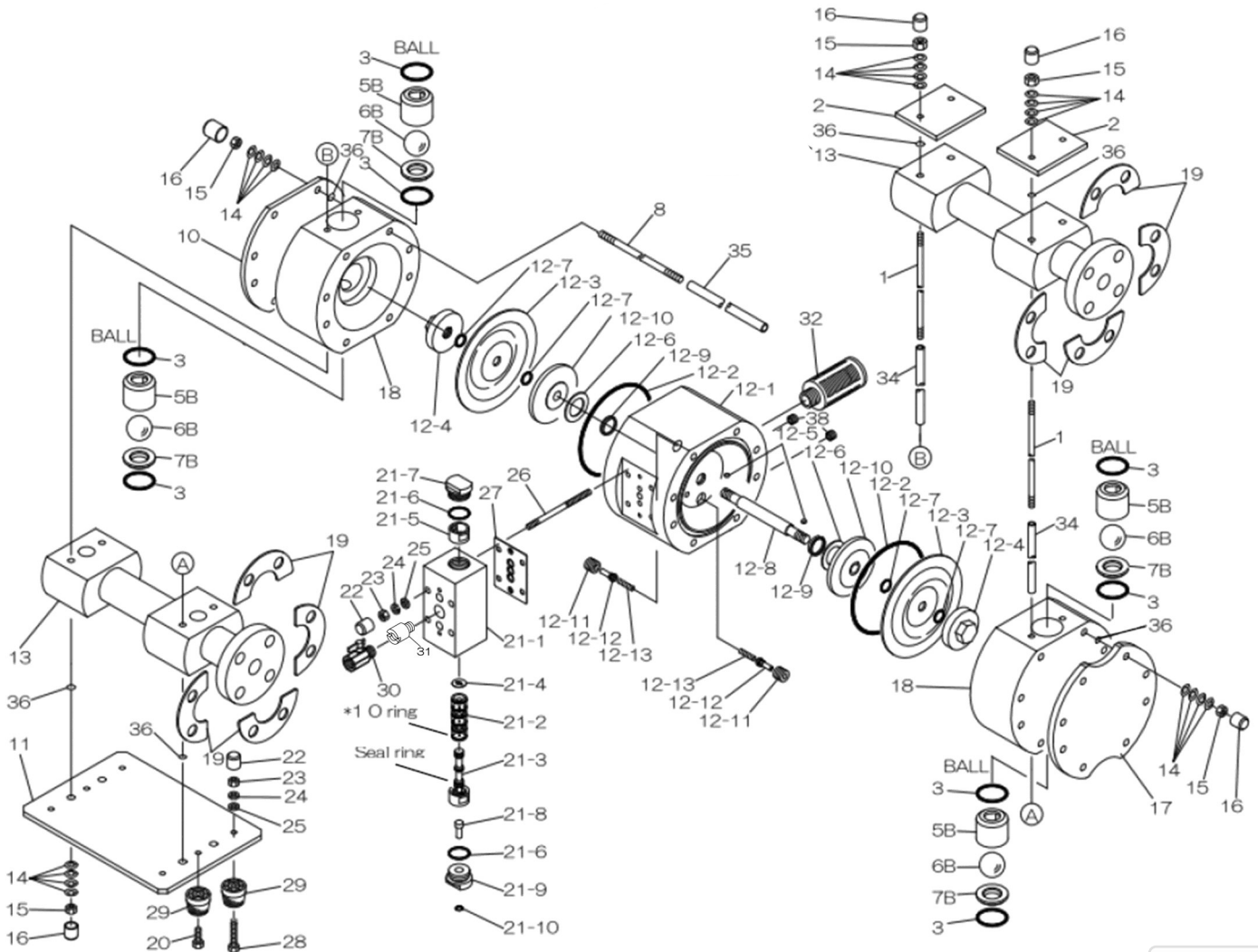

# EXPLODED VIEW & PARTS LISTING

Model: DP-38F Ball Valve  
High Purity Pump  
853705 DP-38F Flange



## Air Operated Double Diaphragm Pump

REF. No.	PARTS NO.	DESCRIPTION	QTY
1	714571	TIE ROD 38F	4
2	771500	PROTECTOR 38F	2
3	643041	O RING	8
5B	772774	BALL GUIDE	4
6B	770691	BALL	4
7B	772770	VALVE SEAT (BALL)	4
8	714572	TIE ROD 38F	8
10	771503	PROTECTOR 38F	1
11	771498	PLATE	1
12	804149	BODY ASSY	1
12-1	772489	BODY 38F	1
12-2	643167	O RING	2
12-3	771814	DIAPHRAGM 38F	2
12-4	780185	CENTER DISK 38F OUTER	2
12-5	771510	STOPPER 38F	2
12-6	772492	CUSHION 38F	2
12-7	643015	O RING	4
12-8	717249	CENTER ROD 38F	1
12-9	685209	PACKING 38F	2
12-10	771506	CENTER DISK 38F INNER	2
12-11	771501	PILOT VALVE SEAT 38	2
12-12	803909	PILOT VALVE ASSY 38	2
12-13	711193	SPRING 38F	2
13	772601	MANIFOLD 38F FLANGE	2
14	681303	LOCK WASHER M10 SS	96
15	683636	NUT 38F M10X1.50	24
16	771644	CAP 38F	24
17	771507	PROTECTOR 38F	1
18	772490	OUT CHAMBER 38F	2
19	711205	PROTECTOR 38F	8
20	621147	BOLT M8X1.25X20 HEX	2
21	804303	VALVE BODY ASSY	1
21-1	832570	VALVE BODY 38F	1
21-2	803747	SLEEVE ASSY 38F	1
21-3	803432	C SPOOL ASSY 38F	1
21-4	703432	CUSHION	1
21-5	771483	SPRING HOLDER 38F	1
21-6	771939	O RING 25.8MM X 3.53MM	2
21-7	642025	CAP 25/38F	1
21-8	771992	RESET BUTTON 25/38F	1
21-9	771940	CAP 25/38F	1
21-10	642005	O RING 7.5MM X 2.0MM	1
22	771786	CAP	8
23	683635	M NUT	8
24	681300	SPRING WASHER	8
25	631173	WASHER	8

26	711194	BOLT 25/38F	4
27	771504	GASKET 38F AIR VALVE	1
28	621155	BOLT M8 X 1.25 X 40 FT	4
29	770551	FOOT RUBBER	6
30	686972	BALL VALVE	1
32	684501	MUFFLER	1
34	772555	TUBE	8
35	772554	TUBE	4
36	642009	O RING 11M X 2.5MM	24
38	771301	PLUG	2
KIT	K38-F-2	KIT FOR DP-38F NEW	
KIT	K25/38-F-BV	KIT FOR DP-25F&38F BALL VALVE	

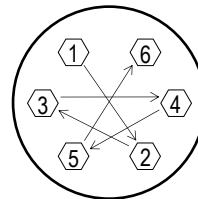

[CLICK HERE FOR TORQUE](#)



### General Tools:

- Socket wrench - 13mm, 17mm
- Open-end wrenches - 13mm, 17mm
- Adjustable angle wrench

### Special Tools (sold separately):

- Sleeve remover (713148)
- Pilot valve remover (712606)
- Torque Wrench (804310) used to retighten the center disk
- PP Wrench (771868) used to remove the center disk

### Miscellaneous:

- Nuts - M16 X 1.5
- Assembly Lubrication Oil - Fomblin® GR AR555 or equivalent for Center Rod (Ref# 12-8)

[CLICK HERE FOR MAINTENANCE MANUAL](#)

### Customer Notes

Model #: \_\_\_\_\_  
Description: \_\_\_\_\_  
Serial #: \_\_\_\_\_  
Date Installed: \_\_\_\_\_  
Department Location: \_\_\_\_\_  
Tag/Project: \_\_\_\_\_