

# EXPLODED VIEW & PARTS LISTING

## Air Operated Double Diaphragm Pump

Model: DP-15FP (FLAT)  
Polypropylene Series

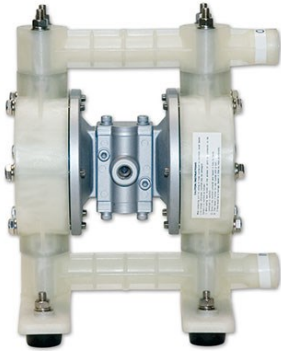

### To Purchase:

- 800-990-7867
- sales@yamadapump.com
- Find My Rep

### More Information:

- YouTube: @yamadapump
- yamadapump.com
- Data Sheets | CAD Drawings | Manuals Literature | BOM | Performance Curves

### Trial Program

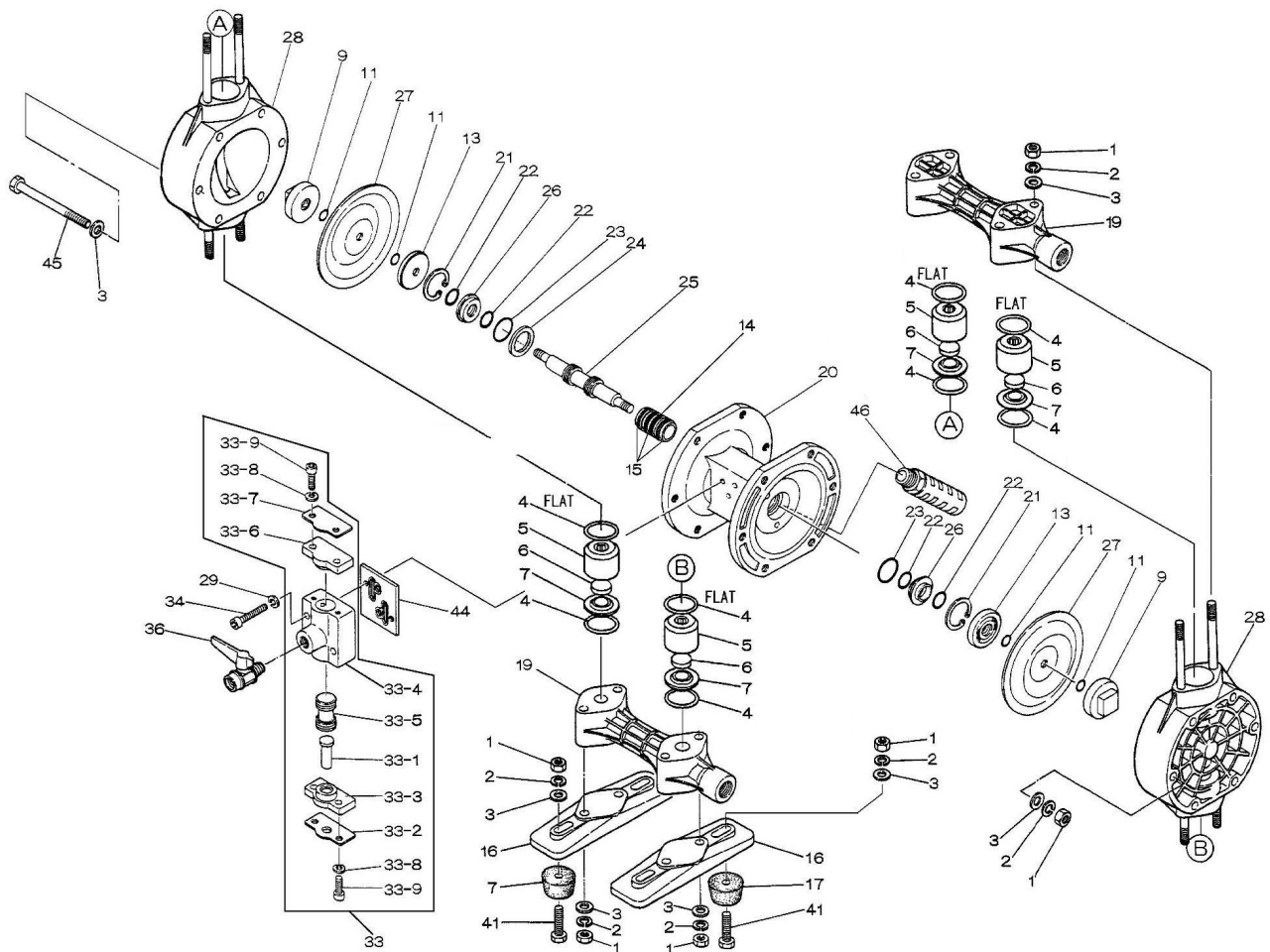

## Air Operated Double Diaphragm Pump

REF. No.	DP-15FPH	DP-15FPN	DP-15FPS	DP-15FPT	DESCRIPTION	QTY.	REORDER
	853721	853717	853723	853719			
	PARTS No.	PARTS No.	PARTS No.	PARTS No.			
1	628012	628012	628012	628012	NUT	12	
2	681300	681300	681300	681300	SPRING LOCK WASHER	24	
1	631329	631329	631329	631329	PLAIN WASHER	24	
4	640027	640027	684115	683027	O-RING	8	
5	771341	771341	771341	771341	VALVE STOPPER	4	
6	771340	771340	771340	771340	FLAT VALVE	4	
7	771345	771345	771345	771345	VALVE SEAT	4	
9	770968	770968	770968	770968	CENTER DISK	2	
11	-	640005	-	643005	O-RING	4	
13	770968	770968	770968	770968	CENTER DISK	2	
14	714678	714678	714678	714678	SLEEVE	1	
15	684900	684900	684900	684900	O-RING	4	
16	771352	771352	771352	771352	BASE	2	
17	770551	770551	770551	770551	CUSHION	4	
19	780190	780190	780190	780190	MANIFOLD	2	
20	715107	715107	715107	715107	BODY	1	
21	630807	630807	630807	630807	RETAINING RING C TYPE	2	
22	684284	684284	684284	684284	PACKING	4	
23	640131	640131	640131	640131	O-RING	2	
24	772651	772651	772651	772651	SPACER	1	
25	801785	801785	801785	801785	CENTER ROD ASSEMBLY	1	
26	772619	772619	772619	772619	GUIDE BUSHING	2	
27	771372	770973	771972	770933	DIAPHRAGM	2	
28	780119	780119	780119	780119	OUT CHAMBER	2	
29	681855	681855	681855	681855	SPRING LOCK WASHER	2	
33	804505	804505	804505	804505	VALVE BODY ASSEMBLY	1	
33-1	706798	706798	706798	706798	PUSH ROD	1	
33-2	710587	710587	710587	710587	REINFORCEMENT PLATE A	1	
33-3	771357	771357	771357	771357	CAP	1	
33-4	710853	710853	710853	710853	SPOOL VALVE CASE	1	
33-5	801404	801404	801404	801404	SPOOL VALVE ASSEMBLY	1	
33-6	771356	771356	771356	771356	CAP	1	
33-7	710636	710636	710636	710636	REINFORCEMENT PLATE B	1	
33-8	681855	681855	681855	681855	SPRING LOCK WASHER	4	
33-9	682943	682943	682943	682943	HEXAGON SOCKET HEAD BOLT	4	
34	682918	682918	682918	682918	HEXAGON SOCKET HEAD BOLT	2	
36	683055	683055	683055	683055	BALL VALVE	1	
41	621153	621153	621153	621153	BOLT	4	
44	771358	771358	771358	771358	GASKET	1	
45	621160	621160	621160	621160	BOLT	12	
46	682520	682520	682520	682520	SILENCER	1	
KIT	K15-PH	K15-PN	K15-PS	K15-PT	LIQUID SIDE		
KIT	K115-AM				AIR MOTOR		

**Air Operated Double Diaphragm Pump**

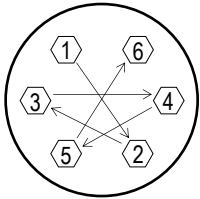

**Tightening torque for center rod and out chambers.**

Center Rod	122 in-lbf {14 N-m}
Out Chambers	105 in-lbf {12 N-m}

**Tightening torque for manifold retainer bolts.**

FPH/N/S/T	105 in-lbf {12 N-m}
-----------	---------------------

**General Tools:**

- Socket wrench - 13mm
- Hexagonal box wrenches - 5mm
- Open-end wrench - 21mm
- Snap ring pliers

**Miscellaneous:**

- Assembly Oil—turbine oil none additional class 1 (equivalent to ISA VGA32 grade)
- Urea grease grade (NLGI) No. 2

**Customer Notes**

Model #: \_\_\_\_\_  
 Description: \_\_\_\_\_  
 Serial #: \_\_\_\_\_  
 Date Installed: \_\_\_\_\_  
 Department Location: \_\_\_\_\_  
 Tag/Project: \_\_\_\_\_